



PERMALOC
ASPHALT EDGE
 ALUMINUM ASPHALT RESTRAINT

PERMALOC ALUMINUM EDGING, 13505 BARRY STREET HOLLAND, MI, 49424
 (800) 356-9660 PHONE: (616) 399-9600 fax: (616) 399-9770 WWW.PERMALOC.COM

ARCHITECT NOTE: CHECK OFF APPLICABLE SIZE & FINISH DESIRED

SIZE: ALL 8' (2.44 M) LENGTHS w/ 0.210" (5.33 MM) THICK EXPOSED TOP LIP

<input type="checkbox"/> 1.5" X 2.25"	(38 MM X 57 MM)	<input type="checkbox"/> MF	<input type="checkbox"/> BL
<input type="checkbox"/> 2" X 2.25"	(51 MM X 57 MM)	<input type="checkbox"/> MF	<input type="checkbox"/> BL
<input type="checkbox"/> 2.5" X 2.25"	(64 MM X 57 MM)	<input type="checkbox"/> MF	<input type="checkbox"/> BL
<input type="checkbox"/> 3" X 3"	(76 MM X 76 MM)	<input type="checkbox"/> MF	<input type="checkbox"/> BL
<input type="checkbox"/> 4" X 3"	(102 MM X 76 MM)	<input type="checkbox"/> MF	<input type="checkbox"/> BL

FINISH LEGEND:

(MF) MILL FINISH-NATURAL ALUMINUM
 (BL) BLACK DURAFLEX-ELECTROSTATICALLY
 APPLIED BAKED ON PAINT, MEETS AAMA 2603

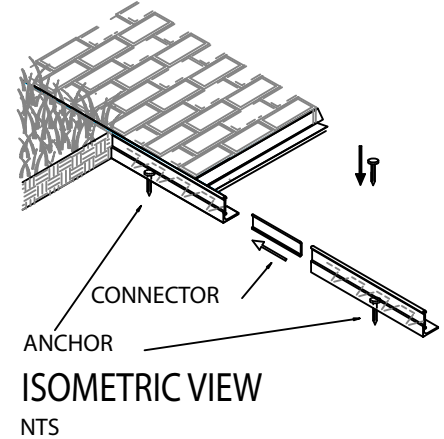

NOTES:

1. INSTALLATION PER MANUFACTURER'S "INSTALLATION GUIDELINES"
2. 8'-0" (2.44 M) SECTIONS CONNECTED WITH 4" (102 MM) SLIDING CONNECTOR.
3. CORNERS: NOTCH BASE ONLY FORM A CONTINUOUS CORNER.
4. PERMALOC ASPHALTEDGE AS MANUFACTURED BY PERMALOC CORPORATION, HOLLAND MI.
 (800) 356-9660,
 (616) 399-9600
5. CONTRACTOR'S NOTE: FOR PRODUCT AND PURCHASING INFORMATION VISIT: WWW.PERMALOC.COM

PERMALOC ASPHALTEDGE
 ALUMINUM RESTRAINT

COMPACT GRADE ADJACENT
 TO RESTRAINT

PAVER & SETTING COURSE

FILL ALL VOIDS UNDER
 RESTRAINT FOR PROPER
 SUPPORT

CONCRETE BASE
 (NEW OR EXISTING)

RAMSET/HILTI 3/4 "-1" (19MM - 25MM)
 NAIL MINIMUM 2.5" (63.5MM) FROM
 EDGE OF CONCRETE,
 12" (305MM) O.C. (TYP)

COMPACT BASE

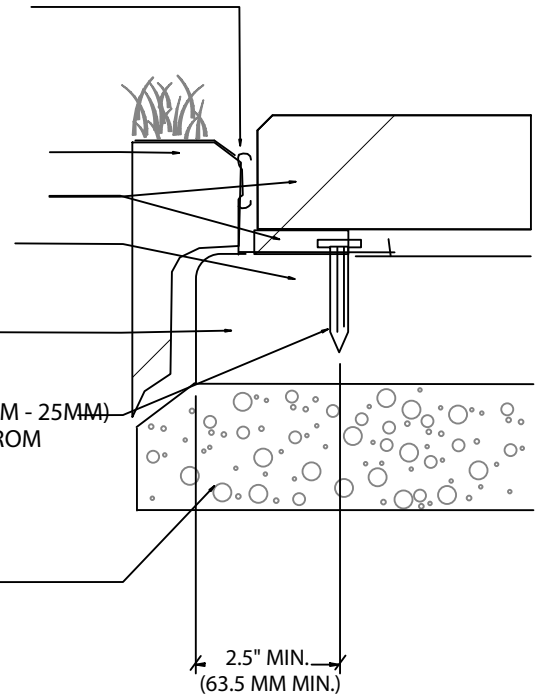

EDGING FOR PAVERS OVER CONCRETE BASE

SCALE: 3"=1'-0"