

BrickBlock™

ALUMINUM PAVER RESTRAINT

PERMALOC CORPORATION, 13505 BARRY STREET HOLLAND, MI, 49424
 (800) 356-9660 PHONE: (616) 399-9600 fax: (616) 399-9770 WWW.PERMALOC.COM

A PRODUCT BY
permaloc
 WORLD'S BEST LANDSCAPE EDGING

ARCHITECT NOTE: CHECK OFF APPLICABLE SIZE & FINISH DESIRED:

SIZE: IN 8' (2.44M) LENGTHS

- .065" X 1³/₄" (1.65MM X 44.5MM)
 w/ 0.070" (1.78MM) TOP LIP MF BL
- .075" X 1³/₄" (1.90MM X 44.5MM)
 w/ 0.080" (2.03MM) TOP LIP MF BL
- .075" X 2-3/4" (1.90MM X 69.9MM)
 w/ 0.080" (2.03MM) TOP LIP MF BL

FINISH LEGEND:

(MF) MILL FINISH-NATURAL ALUMINUM MEETS

NOTES:

1. INSTALL PER MANUFACTURER'S "INSTALLATION GUIDELINES"
2. CONNECTION BETWEEN SECTIONS TO UTILIZE MANUFACTURER'S QUICK CLIP CONNECTOR SYSTEM.
3. CORNERS: NOTCH BASE ONLY AND FORM A CONTINUOUS CORNER.
4. PERMALOC BRICK BLOCK AS MANUFACTURED BY PERMALOC CORPORATION, HOLLAND MI. (800) 356-9660, (616) 399-9600
5. CONTRACTOR'S NOTE: FOR PRODUCT AND PURCHASING INFORMATION VISIT: WWW.PERMALOC.COM

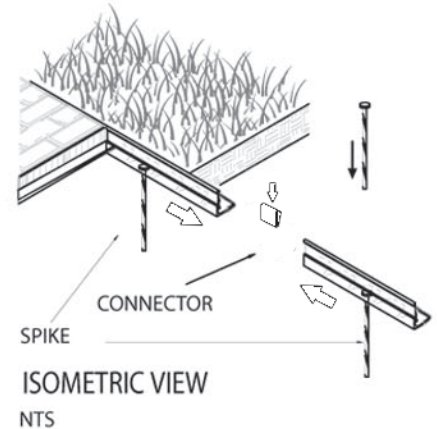

PERMALOC BRICK BLOCK ALUMINUM PAVER RESTRAINT

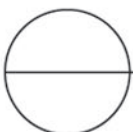
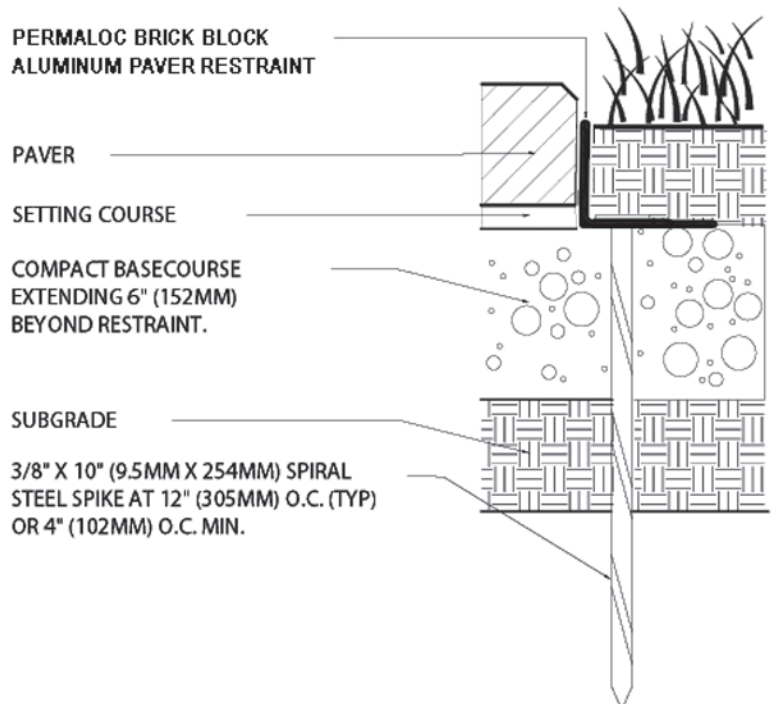

PAVER EDGE DETAIL-TYPICAL INSTALLATION

SCALE: 3"=1'-0"