



ARCHITECT NOTE: CHECK OFF APPLICABLE SIZE & FINISH DESIRED

SIZE:

- 1/8" X 3 1/2" (3.2 MM x 89 MM), 0.060" (1.52 MM) THICK
W/ 0.200" (5.08 MM) EXPOSED TOP LIP
- 3/16" X 3 1/2" (4.8 MM x 89 MM), 0.076" (1.93 MM) THICK
W/ 0.200" (4.83 MM) EXPOSED TOP LIP
- 1/8" X 4" (3.2 MM x 101.6 MM), 0.060" (1.52 MM) THICK
W/ 0.200" (5.08 MM) EXPOSED TOP LIP
- 3/16" X 4" (4.8 MM x 101.6 MM), 0.076" (1.93 MM) THICK
W/ 0.200" (4.83 MM) EXPOSED TOP LIP
- 1/8" X 6" (3.2 MM x 152.4 MM), 0.060" (1.52 MM) THICK
W/ 0.200" (5.08 MM) EXPOSED TOP LIP
- 3/16" X 6" (4.8 MM x 152.4 MM), 0.076" (1.93 MM) THICK
W/ 0.200" (4.83 MM) EXPOSED TOP LIP

FINISH LEGEND:

- (MF) MILL FINISH-NATURAL ALUMINUM
- (BL) BLACK DURAFLEX-ELECTROSTATICALLY APPLIED
BAKED ON PAINT, MEETS AAMA 2603

NOTES:

1. INSTALL PER MANUFACTURER'S "INSTALLATION GUIDELINES"
2. 8'-0" (2.44 M) SECTIONS TO INCLUDE (3) 12" (305 MM) ALUMINUM STAKES.
3. 16'-0" (4.88 M) SECTIONS TO INCLUDE (8) 12" (305 MM) ALUMINUM STAKES.
4. CORNERS: NOTCH BASE ONLY AND FORM A CONTINUOUS CORNER.
5. PERMALOC PERMASTRIP AS MANUFACTURED BY PERMALOC CORPORATION, HOLLAND MI.
(800) 356-9660,
(616) 399-9600
6. CONTRACTOR'S NOTE:
FOR PRODUCT AND PURCHASING INFORMATION VISIT:WWW.PERMALOC.COM

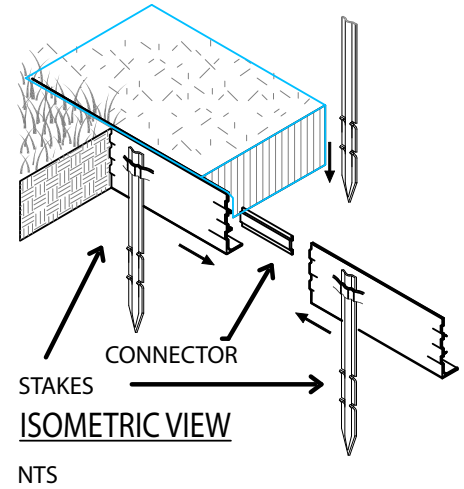

PERMALOC PERMASTRIP ALUMINUM EDGING

TOP OF EDGING TO BE MAXIMUM OF 1/2" (12.7MM) ABOVE SURFACE MATERIAL

COMPACT GRADES ADJACENT TO EDGING TO AVOID SETTLING

STONE OR MULCH

HORIZONTAL BASE FOR EXTRA RIGIDITY

12" (305MM) ALUMINUM STAKES TO LOCK INTO PREFORMED LOOPS ON THE EDGING

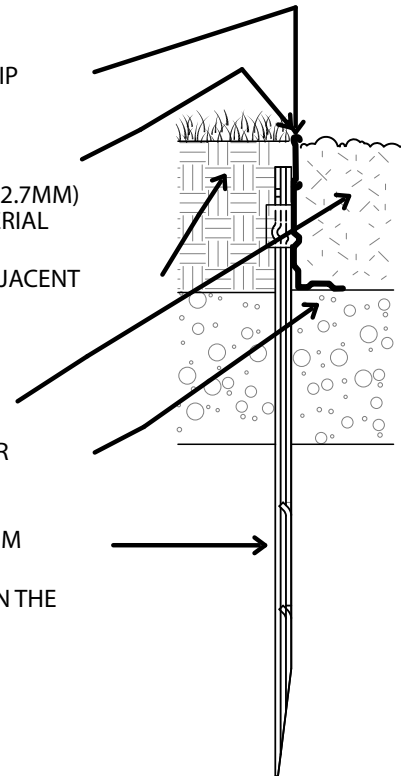

EDGE DETAIL-STONE/MULCH MAINTENANCE STRIP

SCALE: 3"=1'-0"

