

# PROSLIDE™ LT

ALUMINUM LANDSCAPE EDGING

PERMALOC CORPORATION, 13505 BARRY STREET HOLLAND, MI, 49424  
(800) 356-9660 PHONE: (616) 399-9600 fax: (616) 399-9770 WWW.PERMALOC.COM



ARCHITECT NOTE: CHECK OFF APPLICABLE SIZE & FINISH DESIRED

## SIZE:

- 1/8" X 4" (3.2MM X 102MM), 0.050" (1.27MM) THICK  
w/ 0.20" (5.1MM) EXPOSED TOP LIP  MF  BL  GR  BR

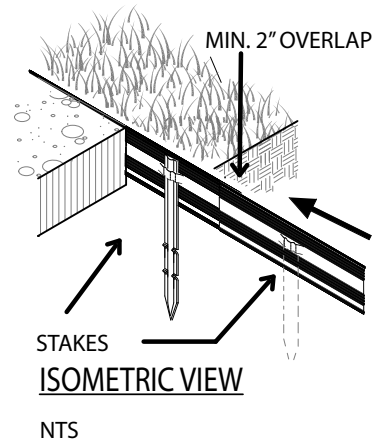

## FINISH LEGEND:

- (MF) MILL FINISH-NATURAL ALUMINUM  
(BL) BLACK DURAFLEX-MEETS AAMA 2603  
(GR) GREEN DURAFLEX-MEETS AAMA 2603  
(BR) BRONZE DURAFLEX-MEETS AAMA 2603

## NOTES:

1. INSTALL PER MANUFACTURER'S "INSTALLATION GUIDELINES"
2. 8'-0" (2.44 M) SECTIONS TO INCLUDE (3) 12" (305 MM) ALUMINUM STAKES.
3. 16'-0" (4.88 M) SECTIONS TO INCLUDE (5) 12" (305 MM) ALUMINUM STAKES.
4. CORNERS - CUT BASE OF EDGING UP HALFWAY AND FORM A CONTINUOUS CORNER.
5. PERMALOC PROSLIDE AS MANUFACTURED BY PERMALOC CORPORATION, HOLLAND MI.  
(800) 356-9660,  
(616) 399-9600
6. CONTRACTOR'S NOTE:  
FOR PRODUCT AND  
PURCHASING INFORMATION  
VISIT:WWW.PERMALOC.COM

PERMALOC  
PROSLIDE LT  
ALUMINUM EDGING

TOP OF EDGING TO  
BE MAXIMUM OF  
1/2" (12.7MM)  
ABOVE SURFACE  
MATERIAL

BED MEDIA OR  
AGGREGATE

COMPACT GRADES  
ADJACENT TO  
EDGING TO AVOID  
SETTLING

12" (305MM)  
ALUMINUM STAKES  
TO LOCK INTO  
PREFORMED LOOPS  
ON THE EDGING

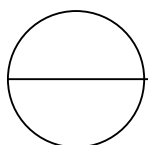

## ALUMINUM LANDSCAPE BED EDGING

SCALE: 3"=1'-0"